Electric Pallet truck

20/25EPR



■ Photo may include optional equipment.

Standard Configurations

20EPR

- Lifting Capacity : 2000 kg
- AC Drive Motor : 1.5 kW (9 km/h)
- Lift motor : 1.2 kW
- Curtis controller
- Drive wheel : 250 x 70 mm
- Double Polyurethane load wheel (size: 82 x 98 mm)
- Hourmeter, battery discharge indicator (BDI) & lift cut off
- Overall Fork Width x Length : 550 mm x 1150 mm
- Turtle switch / crawl speed button
- Tiller head with big control buttons
- Side Battery Removal
- EPS (Electric Power Steering)
- Stand on platform

25EPR

- Lifting Capacity : 2500 kg
- AC Drive Motor : 1.5 kW (6 km/h)
- Lift motor : 1.2 kW
- Curtis controller
- Drive wheel : 250 x 70 mm
- Double Polyurethane Load wheel (size: 82 x 98 mm)
- Hourmeter, battery discharge indicator (BDI) & lift cut off
- Overall Fork Width x Length : 550 mm x 1150 mm
- Turtle switch / crawl speed button
- Tiller head with big control buttons
- Side Battery Removal
- EPS (Electric Power Steering)
- Stand on platform

Advantages

SAFETY AND PRODUCTIVITY

- AC technology gives high performance and low maintenance (no carbon brushes)
- Intelligent regenerative brake system: increase overall truck performance.
- Side battery removal, for multiple shift operation
- Turtle mode switch, for safe maneuverability with tiller in upright position
- Proportional travel speed control
- Anti roll-back on gradients
- Effortless steering (EPS), less fatigue
- Automatic speed reduction relative to steer angle
- Suspended platform for comfortable operation

STRUCTURE DESIGN

- The closed motor structure is water- and dust resistant (IP 44)
- Spring-loaded castors improve lateral stability on uneven floors and enhance truck performance and service life.
- Welded type fork.

SERVICEABILITY

- CANbus technology reduces wiring complexity.
- All pivot points have grease fittings and serviceable bushings, to reduce component-wearing.
- Easy access to all components thanks to removal of 1-piece front cover.

Electric Pallet truck

Dimensions

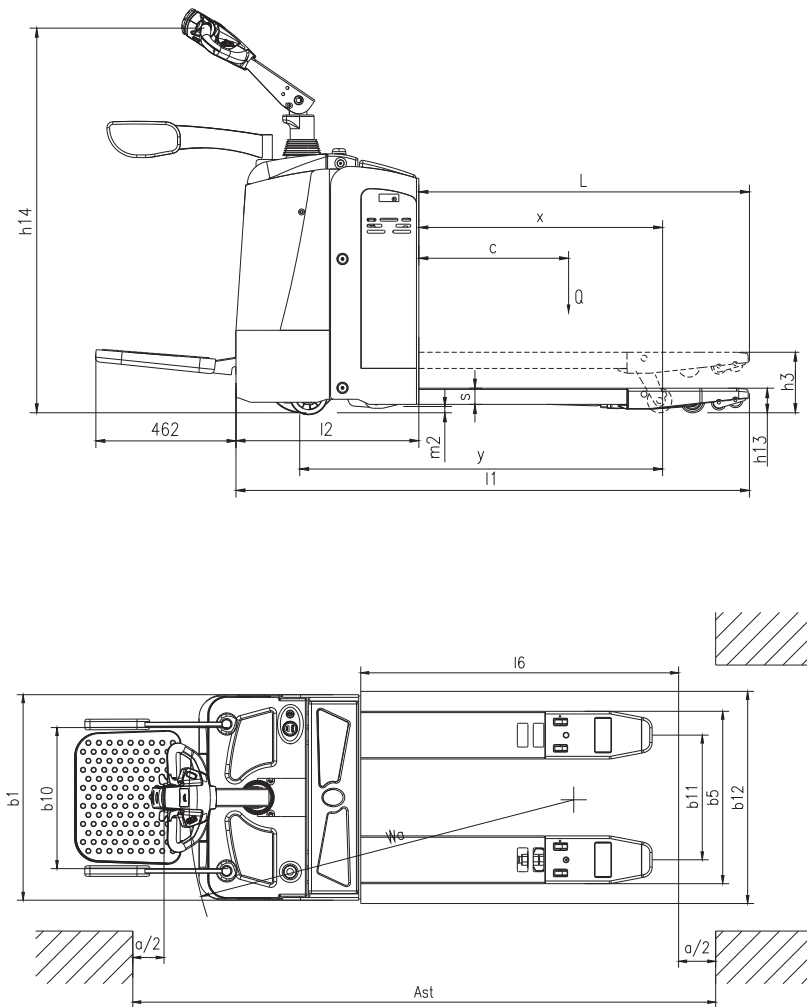

Option

- Traveling speed 6 km/h
(1.6 kw Drive motor, Curtis controller 1232)
- Curtis steering controller
- Integrated charger (24V / 20A)
- Coldstore specification -18°C
- Closed operator protection
- Keyless ignition (keypad) (start)
- Loadguard 1220 mm
- Battery trolley
- Fork length (mm)
 - 20EPR : 800; 900; 1000; 1200; 1600; 1800; 2400
 - 25EPR : 800; 900; 1000; 1200; 1600; 1800; 2400
 - (1800; 2400 : rated load capacity 1.5t)

Specification (according to VDI 2198)

Characteristics					
1.1	manufacturer (abbreviation)			Hyundai	Hyundai
1.2	Model			20EPR	25EPR
1.3	Drive type			Electric	Electric
1.4	Operator type			pedestrian / standing	pedestrian / standing
1.5	Load capacity/rated load	Q	kg	2000	2500
1.6	Load center distance	c	mm	600	600
1.8	Load distance	x	mm	818 / 868 / 938	818 / 868 / 938
1.9	Wheelbase	y	mm	1302 / 1352 / 1422	1302 / 1352 / 1422
Weight					
2.1	Service weight (with battery)		kg	720	720
2.2	Axle load, front/rear, loaded		kg	1640 / 1030	2040 / 1180
2.3	Axle load, front/rear, unloaded		kg	160 / 560	160 / 560
Wheels/Chassis					
3.1	Tyres: solid rubber, super elastic, pneumatic, polyurethane			polyurethane	polyurethane
3.2	Tyre size, front			Φ 250 × 70	Φ 250 × 70
3.3	Tyre size, rear			Φ 80 × 70	Φ 74 × 70
3.4	Additional wheels (dimensions)			Φ 127 × 57	Φ 127 × 57
3.5	Wheels number, front/rear (x = driven wheels)			1x +2/4	1x +2/4
3.6	Tread, front	b10	mm	491	491
3.7	Tread, rear	b11	mm	340 / 370 / 470 / 505	340 / 370 / 470 / 505
Dimension					
4.4	Lift height	h5	mm	120	120
4.9	Min. / Max. height of operation handle, in driving position	h14	mm	1150 / 1450	1150 / 1450
4.15	Height, lowered	h13	mm	75 / 85	75 / 85
4.19	Overall length	l1	mm	1823 / 1873 / 1943	1823 / 1873 / 1943
4.20	Length to fork face	l2	mm	723	723
4.21	Overall width of truck body	b1	mm	733	733
4.22	Fork dimension	s/e/l	mm	53 × 180 × 1100 (1150 / 1220)	53 × 180 × 1100 (1150 / 1220)
4.25	Overall width of fork	b5	mm	520 / 550 / 650 / 685	520 / 550 / 650 / 685
4.32	Wheelbase ground distance	m2	mm	30	30
4.33	Aisle width, with pallet 1000 x 1200 crosswise	Ast	mm	2135 / 2185 / 2255	2135 / 2185 / 2255
4.34	Aisle width, with pallet 800 x 1200 lengthwise	Ast	mm	2235 / 2235 / 2255	2235 / 2235 / 2255
4.35	Turning radius	Wa	mm	1700 / 1750 / 1820	1700 / 1750 / 1820
Performance Data					
5.1	traveling speed, loaded/unloaded		km/h	7.9 / 8	6.7 / 6.8
5.2	Lifting speed, loaded/unloaded		m/s	0.03 / 0.032	0.03 / 0.032
5.3	Lowering speed, loaded/unloaded		m/s	0.032 / 0.03	0.032 / 0.03
5.7	Gradeability, loaded/unloaded		%	4 / 8	3 / 8
5.8	Max. gradeability, loaded/unloaded			8 / 20	6 / 20
5.10	traveling brake			electromagnetic brake	electromagnetic brake
Motor					
6.1	Driving motor power		kW	1.5	1.5
6.2	Lifting motor power		kW	1.5	1.5
6.4	Battery voltage/rated capacity		V/Ah	24 / 240	24 / 240
6.5	Battery weight		kg	240	240