Electric Stacker

15ESR



■ Photo may include optional equipment.

Standard Configurations

15ESR

- Lifting Capacity : 1500 kg
- AC Drive Motor : 1.5 kW
- 8.5 km/h
- Lift motor 3.2 kW
- Curtis controller
- Drive wheel : 250 x 70 mm
- Double Polyurethane Load wheel (size: 84 x 80mm)
- Hourmeter, battery discharge indicator (BDI) & Limiter with lift cut off
- Duplex 3.0 m Mast with free lift
- Fork Width x Length : 570 mm x 1150 mm
- Turtle switch / crawl speed button
- German Frei tiller with convenient control buttons
- Proportional Lifting
- Automatic speed reduction (lifting over 1.8 m)
- Belly switch
- Side battery removal
- Stand on platform
- EPS (Electric Power Steering)
- Travel speed reduction

Advantages

SAFETY AND PRODUCTIVITY

- AC technology gives high performance and low maintenance (no carbon brushes)
- Mast lowering damping cushion
- Multi-functional display with BDI and hour meter etc.
- Side battery removal for multiple shift operation
- Auto deceleration function.
- Turtle mode switch, for safe maneuverability with tiller in upright position.
- Proportional travel speed control.
- Effortless steering (EPS), less fatigue
- Suspended platform for comfortable operation
- Intelligent regenerative brake system for fast and efficient handling
- Precision in handling due to proportional hydraulics
- Anti roll-back on gradients (parking brake)
- Lift limit switch shuts off liftmotor at max lifting height

STRUCTURE DESIGN

- The closed motor structure is water- and dust resistant (IP 44)
- Spring-loaded castors improve lateral stability on uneven floors and enhance truck performance and service life.
- Welded type fork.
- Lifting height up to 5600 mm

SERVICEABILITY

- CANbus technology reduces wiring complexity.
- All pivot points have grease fittings and serviceable bushings, to reduce component-wearing.
- Easy access to all components thanks to removal of 1-piece front cover.

Electric Stacker

Dimensions

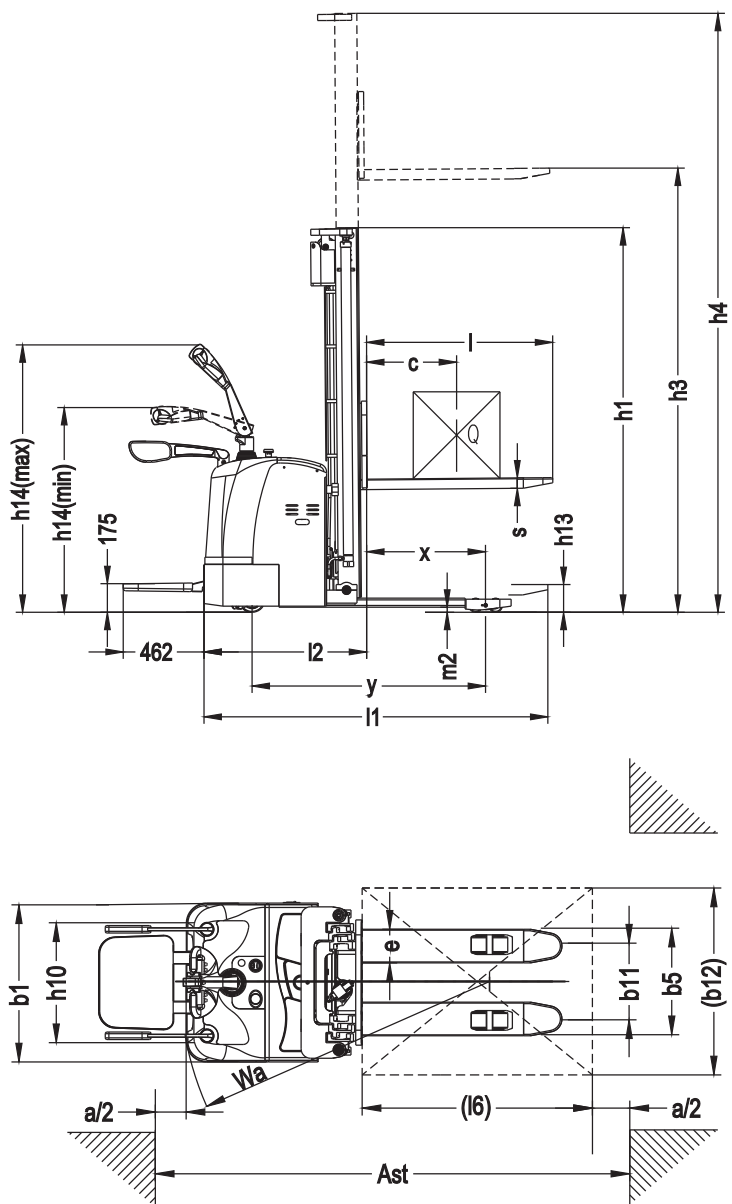

Option

- Traveling speed 6 km/h
- Integrated Charger (24V / 40A)
- Coldstore specification -18°C
- Keyless ignition (keypad)
- Battery trolley
- Initial lift
- Fork length (mm) 800; 900; 1000; 1200

- Lifting height 2500 mm, Duplex mast without free lift
- Lifting height 3000 mm, Duplex mast without free lift
- Lifting height 3300 mm, Duplex mast without free lift
- Lifting height 3500 mm, Duplex mast without free lift
- Lifting height 2500 mm, Duplex mast with free lift
- Lifting height 3500 mm, Duplex mast with free lift
- Lifting height 4500mm, Triplex mast with free lift
- Lifting height 5000mm, Triplex mast with free lift
- Lifting height 5600mm, Triplex mast with free lift

Specification (according to VDI 2198)

Characteristics				
1.1	manufacturer (abbreviation)			Hyundai
1.2	Model			15ESR
1.3	Drive type			electric
1.4	Operator type			pedestrian / standing
1.5	Load capacity/rated load	Q	kg	1500
1.6	Load center distance	c	mm	600
1.8	Load distance	x	mm	672
1.9	Wheelbase	y	mm	1378
Weight				
2.1	Service weight (with battery)		kg	1280
2.2	Axle load, front/rear, loaded		kg	1470/1310
2.3	Axle load, front/rear, unloaded		kg	900/380
Wheels/Chassis				
3.1	Tyres: solid rubber, super elastic, pneumatic, polyurethane			polyurethane
3.2	Tyre size, front			φ 250 × 70
3.3	Tyre size, rear			φ 80 × 84
3.4	Additional wheels (dimensions)			φ 150 × 60
3.5	Wheels number, front/rear (x = driven wheels)			1x +2/4
3.6	Tread, front	b10	mm	580
3.7	Tread, rear	b11	mm	404 / 530
Dimension				
4.2	Height of mast, lowered	h1	mm	1735 / 1985 / 2135 / 2235 / 2050 / 2210 / 2410
4.4	Lift height	h5	mm	1300 / 1550 / 1700 / 1800 / 1570 / 1740 / 1940
4.5	Max. height of mast, extended	h3	mm	2500 / 3000 / 3300 / 3500 / 4500 / 5000 / 5600
4.7	Lifting height for leg	h4	mm	2955 / 3455 / 3755 / 3955 / 5070 / 5550 / 6150
4.9	Min. / Max. height of operation handle, in driving position	h14	mm	1150 / 1450
4.15	Height, lowered	h13	mm	90
4.19	Overall length	l1	mm	2020 / 2100
4.20	Length to fork face	l2	mm	950
4.21	Overall width of truck body	b1	mm	850
4.22	Fork dimension	s/e/l	mm	60 / 180 / 1070 (1150)
4.25	Overall width of fork	b5	mm	570 / 695
4.32	Wheelbase ground distance	m2	mm	31
4.33	Aisle width, with pallet 1000 x 1200 crosswise	Ast	mm	2535
4.34	Aisle width, with pallet 800 x 1200 lengthwise	Ast	mm	2515
4.35	Turning radius	Wa	mm	1655
Performance Data				
5.1	traveling speed, loaded/unloaded		km/h	8.5 / 8.7
5.2	Lifting speed, loaded/unloaded		m/s	0–0.12 / 0–0.19
5.3	Lowering speed, loaded/unloaded		m/s	0–0.35 / 0–0.12
5.8	Max. gradeability, loaded/unloaded			8 / 15
5.10	traveling brake			electromagnetic brake
Motor				
6.1	Driving motor power		kW	1.5 (AC)
6.2	Lifting motor power		kW	3.2
6.4	Battery voltage/rated capacity		V/Ah	24 / 300
6.5	Battery weight		kg	300